



T 250 A2

ELECTROMECHANIC TURNSTILE

- Strong Mechanism
- Intense Usage
- Trouble-free Long Years
- Vandal-proof
- Reliable
- Spare Parts Support
- Indoor & Outdoor Conditions

T 250 A2

ELECTROMECHANIC TURNSTILE

T 250 A2 tripod turnstile provides the basic access control solution to secure various locations worldwide. The mechanism is designed and manufactured by MAKİM to ensure long years of trouble free use, especially for locations with intense passage flows.

Application

T 250 A2 can be installed and used trouble-free in various locations like public transportation terminals, universities, banks, business centers, museums, sport centers and amusement parks etc.

Basic Materials

T 250 A2 is produced in AISI 304 stainless steel. All arms and body are made of 304 stainless steel and the core is made of aluminum material against corrosion. T 250 A2 has angled top cover as different from basic model. As an option, it can be produced from 316 stainless steel. The inner main mechanism of T 250 A2 is produced with special investment casting technology, which makes the whole system a lot more robust and lasting. The electronic boards are designed by the qualified engineers of Makim, enabling T 250 A2 operate in various modes and integrations.

General Usage

T 250 A2 electromechanic turnstile operates bidirectionally. Any kind of access control system like card reader, biometric reader, remote control unit or push button can be integrated to T 250 A2 via simple dry-contact. Once the access right is granted, user should touch slightly to T 250 A2 arm in order to make it rotate. After the tripods complete one turn, T 250 A2 is automatically locked. If the user does not use the passage right in 15 seconds, T 250 A2 will give buzzer warning and it will be locked. Status indicator LED lights are located on both sides of T 250 A2, in green arrow and red cross shape to show allowed passage directions. Passage rate is upto 30 person/minute.

Safety

In case of power cut, T 250 A2 is unlocked to allow free rotation of the arms in both sides. As an optional, Makim can produce T 250 A2 with drop-arm mechanism. In this case, once T 250 A2 receives a signal from the emergency system, the blocking arm will drop to provide a completely free passage lane for quick evacuation of the area.

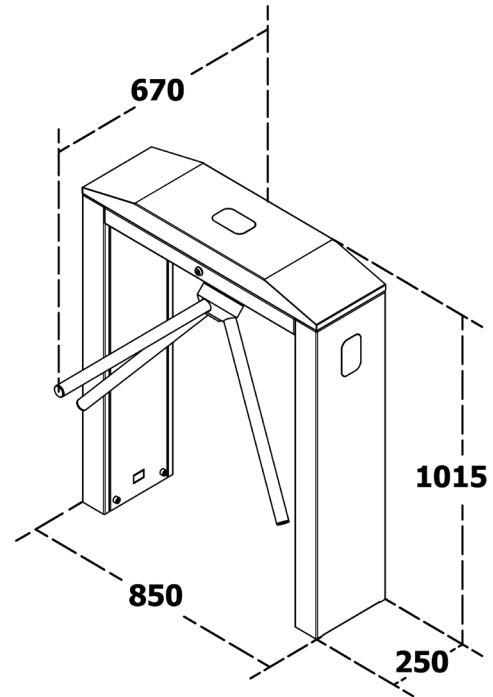

Control /Operation Voltage	100-230 VAC 50/60 Hz
Power Consumption	30 W
Operation Temperature	- 20° C - + 70° C With Optional Heater - 30° C
Passage Speed	30 P / Min.
Passage Range	Min. 42 cm / Max. 47 cm
Weight	31 Kg
Usage Arega	Indoor / Outdoor (If the cover is silikon)
Optional Accessories	Drop-arm, remote control, button unit, card reader,biometric reader, counter
Protection	IP 54 (Op. Ip 65)
Security Level	●●●●○